

auto electrical parts

Technical Information Sheet

Part No. 0-767-28

Stop and tail lamp with optically reflector, plug and sealing gasket. 95mm diameter. Requires connector 0-012-93. Supplied without bulb. Protected to IP67. ECE approved.

Additional Information

An optional mounting bezel is available part 0-767-99.



Technical Drawing (not to scale)

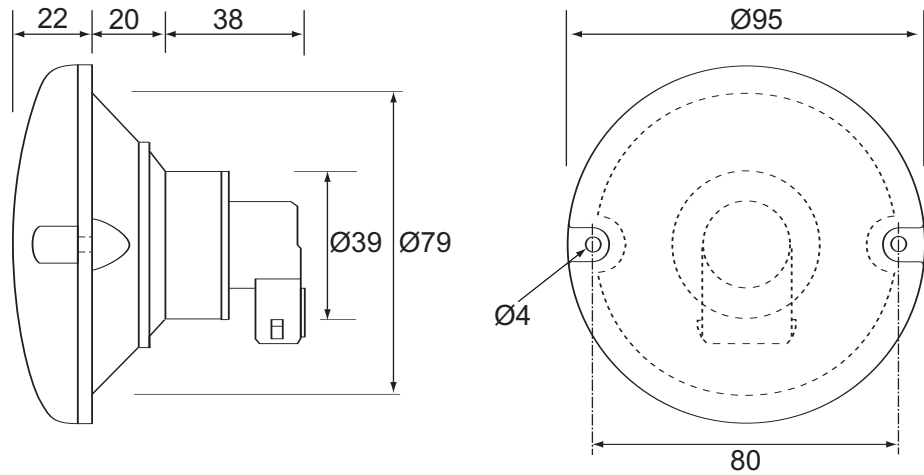

Specification

Type	Stop and tail lamp
Voltage rating	12 - 24 volt dc
Bulb	SBC
Lens material	Acrylic
Connector	3 pin male 'Packard' timer
Weight	80g
Dimensions	95mm dia x 78mm
Approvals	ECE
Protection	IP67

The information contained in this document is correct to the best of our knowledge at the time of printing. However, specifications may change at any time without notice.